

 **PT Thubas Liftindo Perkasa**

PT Thubas Liftindo Perkasa

Head Office

Gang Wates Kp. Rawa Banteng No.102 Rt 003/01 Ds. Mekarwangi
Kec. Cikarang, Barat, Kabupaten Bekasi, Jawa Barat 17530

Branch Office

Bypass Pandaan, Jl. Raya Surabaya - Malang No.8, Sukorejo,
Karang Jati, Kec. Pandaan, Pasuruan, Jawa Timur 67156

Mobile : +62 878 4688 0298
Email : cs.thubaslifindoperkasa.com
Website : thubaslifindoperkasa.com

Engine

XINCHAI
4D35ZG31 / 3.47L

Fuel type

Diesel

Load capacity @ 500 mm LC

5,000 kg

CPCD50

DIESEL
LOADER C
PNEUMATIC TIRES

 **LIUGONG**



Tough world. Tough equipment.

CPCD50 Specifications >>>

Are common	Model	1			CPCD50	
	Fuel type	2			Diesel	
	load capacity	3	With designated DH	kg	5,000	
	Center of gravity	4		mm	500	
Weight	Operating weight	5	without load	kg	6,800	
	axle load	6	loaded front/rear	kg	10.610/3.040	
		7	unloaded front/rear	kg	1.265/3.760	
Tires	Tire type	8			Pneumatic	
	wheels	9	front/rear		2/2	
	Wheelbase	10		mm	2,100	
	Tire size	eleven	front			300-15-18PR
		12	rear			7.00-12-12PR
	Track width	13	front/rear			1.190/1190
Mast	Max. fork height	14	standard two-piece mast	mm	3,000	
	free lift	15	standard two-piece mast	mm	190	
	Height, mast down	16	standard two-piece mast	mm	2,285	
	Height, mast raised	17	standard two-piece mast	mm	4,210	
	Mast tilt forward/back	18	standard two-piece mast	deg	6°/ 12°	
	Carriage	19	width	mm	1,400	
		20	minimum/maximum	mm	310/1,360	
	Fork dimensions	21	T x W x D	mm	50x150x1.070	
Chassis	Fork back length	22	standard two-piece mast	mm	3.208	
	Overall width	23		mm	1.483	
	Head Guard Height	24		mm	2.317	
	turning radius	25	minimum external	mm	2,850	
		26	standard two-piece mast	mm	563	
	Min. turning aisle width	27	cargo length and stock	mm	4,850	
	Clearance	28	at minimum load	mm	165	
29		in the center of the wheelbase	mm	200		
Performance	Travel speed	thirty	with/without load	km/h	24.5/25.5	
	lifting speed	31	with/without load	m/s	550/580	
	Lowering speed	32	with/without load	m/s	520/480	
	Max. pulling force	33	loaded front/rear	kg	2,800	
	max. gradeability	34	with load / without load	%	25/29.5	
Systems	brakes	35	worker		Foot/pneumo-hydraulic booster	
		36	parking lot		manual/mechanical	
		37	manufacturer		xinchai	
	Engine	38	model			4D35ZG31-008
		39	compliance with emission limit values			CHN Stage III
		40	cylinders			4
		41	engine capacity	liters		3.47
		42	power	kW/rpm		60/2,200
		43	Max torque	Nm/rpm		300/1,800

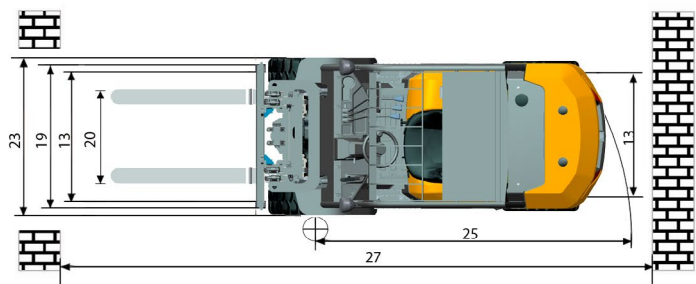
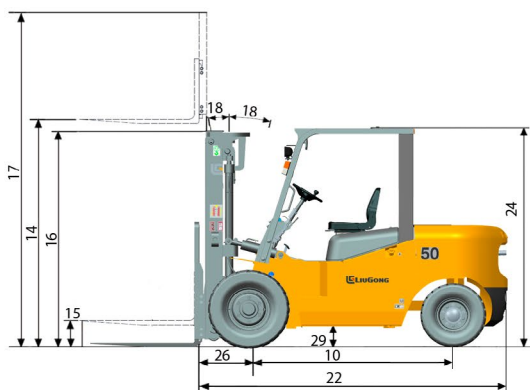

guangxi liugong machinery co., ltd.

no. 1 Liutai Road, Liuzhou, Guangxi 545007, PR China
T: +86 772 3886124 E: overseas@liugong.com

www.liugong.com

Specifications and designs are subject to change without notice. Machines shown may include optional equipment.

10/2019 Designed by LiuGong