



Model  
engine's type  
Control  
load capacity

CLG2020L-R4/N  
Electric  
Walking / Standing  
2000 kg

# CLG2020L-R4/N SELF-PROPELLED CART

# SPECIFICATION

Main settings			
Model	CLG2020L-R4/N		
engine's type	Electric		
Control	Folding platform		
load capacity	Q (t.)	2.0	
Center of gravity	c (mm)	600	
Distance from axle center to forks	x (mm)	965	1083
Wheelbase	y (mm)	1388	1524

Masses			
Weight	kg	965	1083
Front/rear axle load with load	kg	1388	1524
Load on the front / rear axle without load	kg	634	610
		(Flip-down platform with protective handrails)	

wheels			
Wheel type	Polyurethane(PU)		
Front wheel size	xw(mm)	230×75	
Rear wheel size	xw(mm)	84×84	82×110
Additional wheels (dimensions)	xw(mm)	100×40	
Number of wheels front/rear (x-driven)	1x+2/2;+2/4		
Front wheel track	b10 (mm)	500	
Rear wheel track	b11 (mm)	367	512

Dimensions			
lifting height	h3 (mm)	120	
Handle height min./max.	h14 (mm)	946 / 1338	
Fork height in lower position	h13 (mm)	85	83
Overall length	l1 (mm)	1762	1850
Fork back length	l2 (mm)	612	630
Overall width	b1 (mm)	729	
Fork dimensions	s/e/l (mm)	60 / 173 / 1150	60/173/1220
Fork width	b5 (mm)	540	685
Clearance in the center of the base	m2 (mm)	25	23
Aisle width with pallet 800 x 1200	Ast(mm)	2250	2385
Turning radius	Wa(mm)	1585	1720

Technical data		
Travel speed with/without load	km/h	6.0 / 6.0
Lifting speed laden/unladen	m/s	0.027 / 0.035
Fork lowering speed with/without load	m/s	0.042 / 0.027
Max. gradeability with/without load	%	6 / 10
Brake system	Electromagnetic	

Electrical system parameters		
Drive motor power S2 60min	kW	1.3
Lift motor power S3 10%	kW	0.8
Battery in accordance with DIN 43531/35/36A,B,C, norm	B,2Pzb	
Supply voltage, nominal battery capacity K5	V/Ah	24/180
Battery weight (+/-5%)	kg	215
Energy consumption according to VDI cycle	kWh/h	0.75

Additional data			
Controller	AC - speed control		
Noise level according to EN 12053	dB(A)	<70	<70

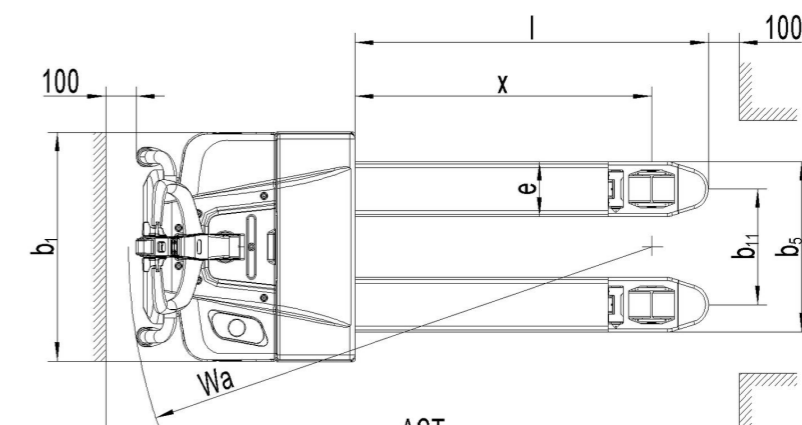
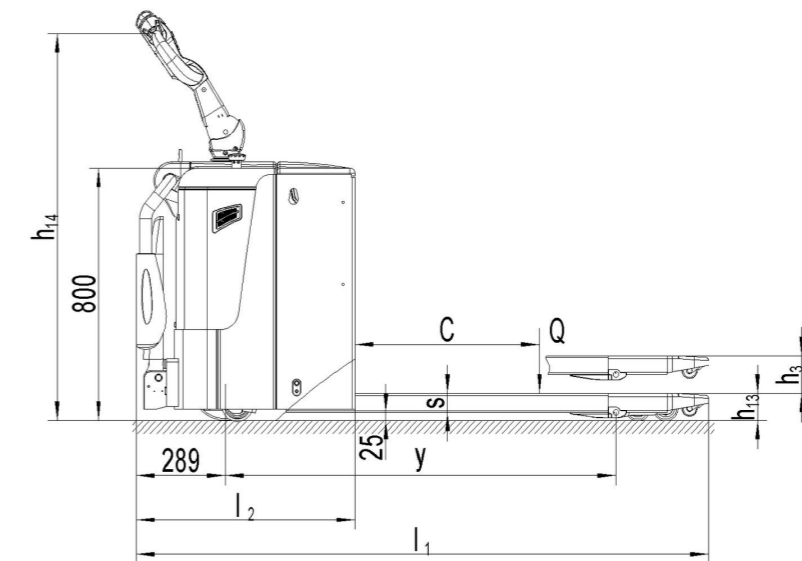



## PT Thubas Liftindo Perkasa

### PT Thubas Liftindo Perkasa

#### Head Office

Gang Wates Kp. Rawa Banteng No.102 Rt 003/01 Ds. Mekarwangi  
Kec. Cikarang, Barat, Kabupaten Bekasi, Jawa Barat 17530

#### Branch Office

Bypass Pandaan, Jl. Raya Surabaya – Malang No.8, Sukorejo,  
Karang Jati, Kec. Pandaan, Pasuruan, Jawa Timur 67156

Mobile : +62 878 4688 0298  
Email : cs.thubaslifindoperkasa.com  
Website : thubaslifindoperkasa.com



### Liuzhou LiuGong Forklift Co., Ltd.

no. 1 Liutai Road, Liuzhou, Guangxi 545007, China  
LiuGong representative office in Armenia  
t.: +( 374) 98 90 90 97 | +(374) 10 43 44 77 |  
email: specmashllc@mail.ru | specmash.am

Like and follow us:



LG-PB-CLG2020L-R4/N-012021-EN

The LiuGong series of logos herein, including but not limited to word marks, device marks, letter of alphabet marks and combination marks, as the registered trademarks of Guangxi LiuGong Group Co., Ltd. are used by Guangxi LiuGong Machinery Co., Ltd. with legal permission, and shall not be used without permission. Specifications and designs are subject to change without notice. Illustrations and pictures may include optional equipment and may not include all standard equipment. Equipment and options vary by regional availability.